

ASCO
NUMATICS™

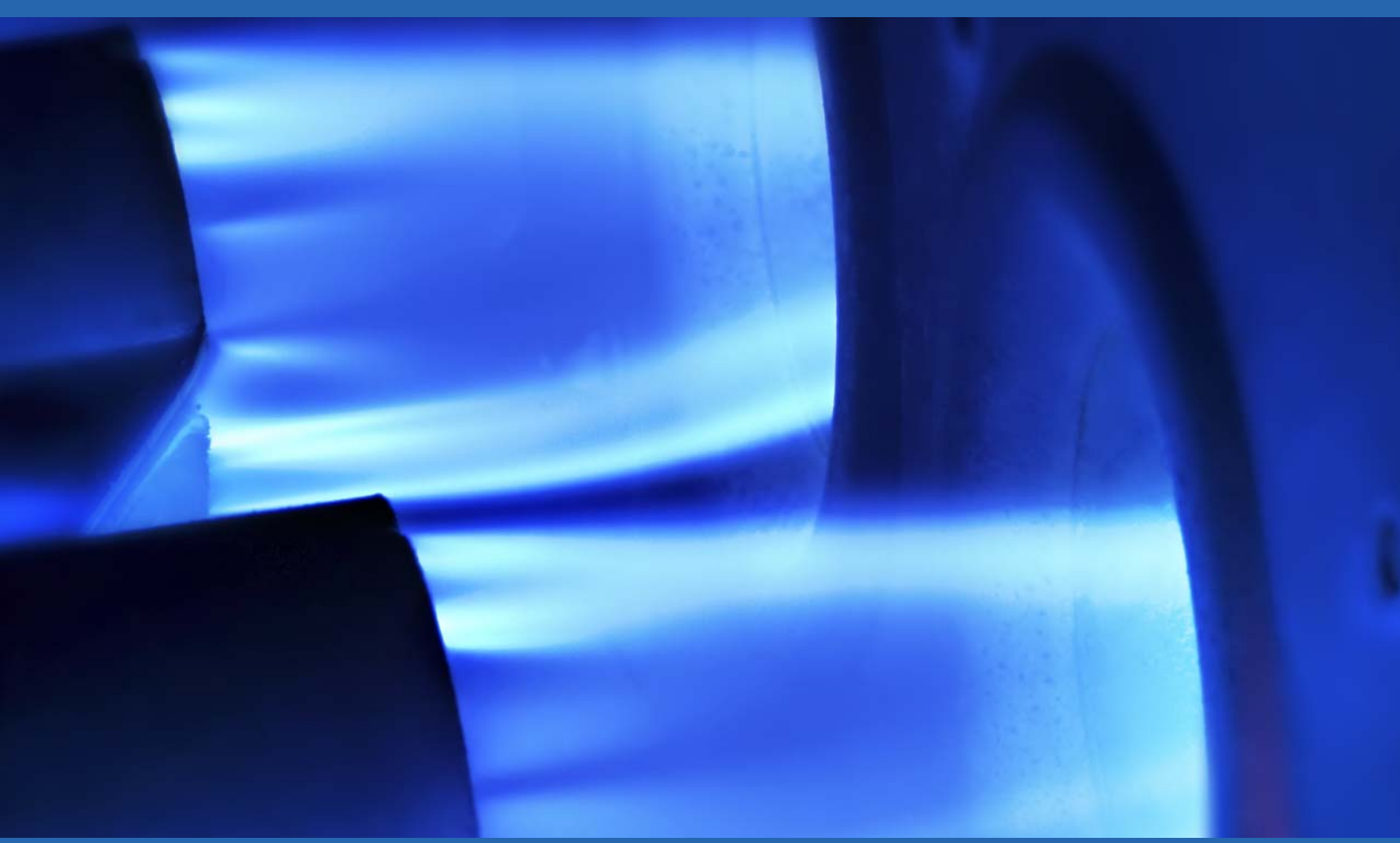

Fluid Automation Solutions

for Heating Equipment

www.asconumatics.com

EMERSON™
Industrial Automation



ASCO Numatics provides the industry's best combination of availability, reliability, and economy for critical heating automation equipment. OEMs and end users alike specify our wide range of innovative yet dependable products.

Presenting ASCO Numatics solutions

Your hot picks for heating

For more than 75 years, our products have furnished top-quality automation for commercial/industrial, process, and nonresidential comfort heating, as well as for generation of power and steam. Today, ASCO Numatics is a key heating automation source for original equipment manufacturers (OEMs), distributors, valve train assemblers, combustion system packagers, architect/engineers, and end users around the world.

For example, we provide more solenoid-operated combustion valves to the nonresidential heating equipment market than any other supplier. That's no surprise. The industry knows that ASCO Numatics knows heating. We leverage that knowledge to provide the best values and the most dependable product lines around.

Exceptional advantages

Superior availability. Unlike some other heating automation suppliers, we won't leave you cold. ASCO Numatics offers the best availability in the industry. Many of our most popular products are available via the ASCO Today and 5 Day shipping programs. Our global distribution network can make sure you get what you need — right when you need it.

Renowned reliability. Our products offer the most dependable operation and highest value available, as well as long life expectancies. So you can count on unbeatable uptime. Our ASCO solenoid valves are famous for extended service life. ASCO coils outlast competitive designs by factors of two or more.

Wide range and ready customization. ASCO Numatics offers a comprehensive array of standard products in differing pipe sizes, pressure ratings, electrical enclosures, and wiring terminations. We also outcustomize the competition, readily developing customer specific designs to meet non-standard needs.



Oil Shutoff Valves

Low cost of ownership. Cost savings run deep in every ASCO Numatics product. Our new modular double gas shutoff valve reduces labor with a flexible two-piece design, and cuts inventory expenses with broad ambient temperature capability. Our new steam and hot water valve halves inventory costs with its dual-purpose design, cuts energy expenditures via low power consumption, and helps eliminate downtime and maintenance with long life and ease of serviceability.

World-class support, worldwide. As part of the Emerson Industrial Automation Group, ASCO Numatics has got you covered. Via phone, e-mail, or onsite visits, our experienced representatives provide the industry's best technical support and service, around the clock — and around the globe.

Key solutions

Pilot Gas Shutoff Valves

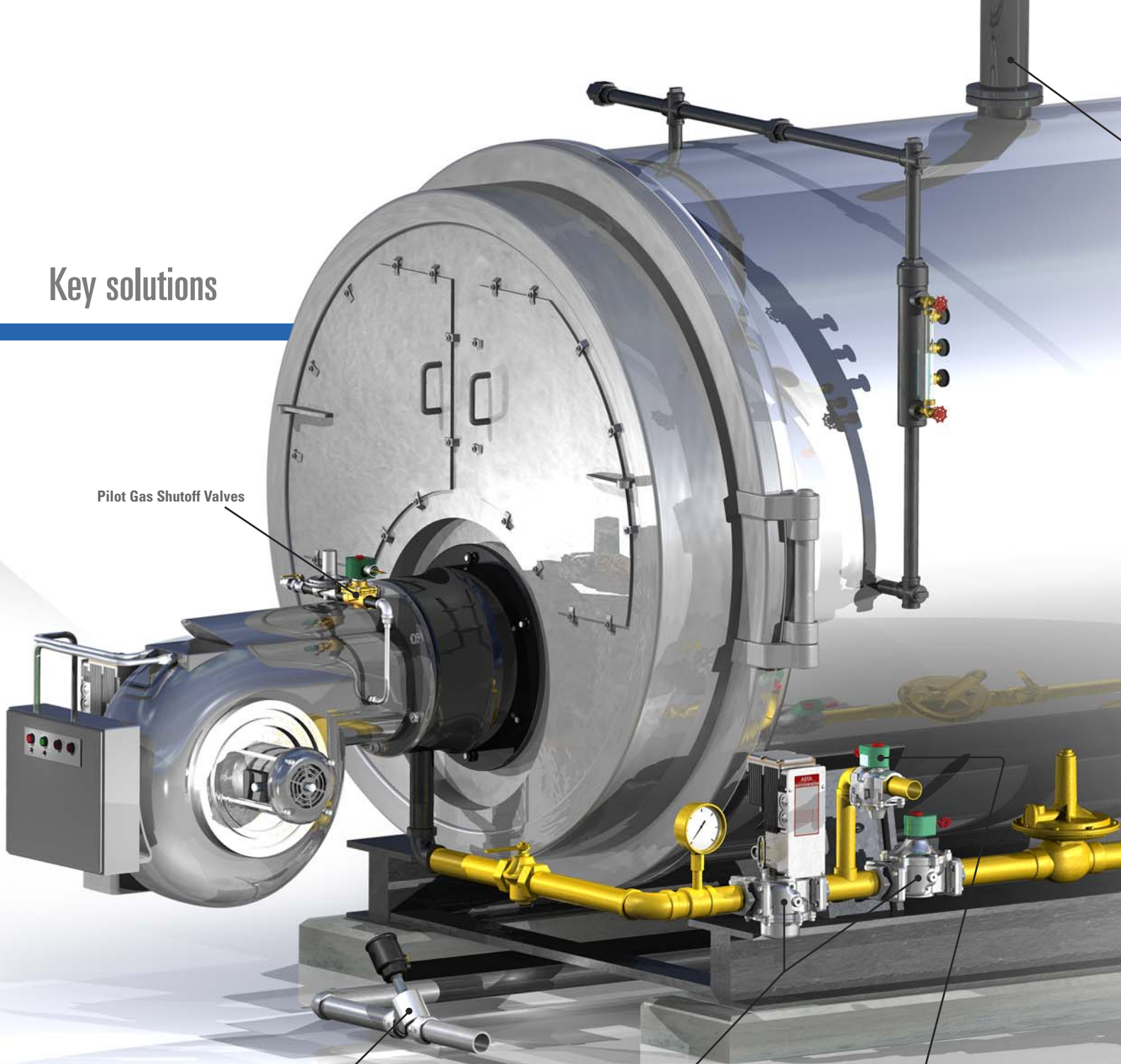

ASCO Angle-Body Piston Valves

These rugged models are designed for air, inert gas, water, and light slurries up to 240 psi as well as high-pressure steam up to 150 psi in pipe sizes 2-1/2 inches or smaller. They allow rapid cycling, prevent water hammer, and create tight shutoff in both directions. Specify these valves for industrial/process applications requiring higher pressures and flows.



ASCO Combustion Valves

Choose from the industry's broadest line of solenoid and electrohydraulic fuel gas, and oil shutoff valves. Leading OEMs specify products for main and pilot gas trains and fuel oil lines in burners, boilers, ovens, furnaces, and kilns. Some models combine extremely high flows with compact designs for economical fuel train downsizing.



ASCO Combustion Ventilation Valves

No other supplier can match our broad offering of normally open solenoid vent valves. They're ideal for larger fuel/gas applications when mandated by code or underwriter requirements for double block and vent constructions.



ASCO Steam and Hot Water Valves

Only these popular high-flow, long-life, easy-maintenance models can provide up to 60% higher flow than competing designs while increasing throughput. They also shrink inventories by accommodating both steam and hot water service. Apply them in industrial/commercial boilers, heavy-duty washers, sterilizers, and other equipment that produces or uses high-temperature fluids.



Numatics FRLs, Pneumatic Actuators, Fittings, and Accessories

Our high-performance filters, regulators, and lubricators provide superior treatment of air quality and pressure, and are available in multiple configurations. Cylinders supply positive actuation for large firebox kiln doors. Pneumatic conveying equipment transports parts through metal curing and drying ovens as well as many other applications. Standardize on Numatics products to help minimize inventories for both OEMs and end users.



ASCO Accessories

Condensate drain valves automatically draw off condensate in compressed air and boiler systems. Strainers installed on fuel and/or water lines filter foreign particles, keeping valves and pressure regulator seats contamination-free. Flow control valves installed on general service (inert gas/water/light oil) and hot water inlet/outlet lines manage media flows. Use these and other reliable ASCO accessories to consolidate and minimize inventories today.

Pilot Gas Shutoff Valves

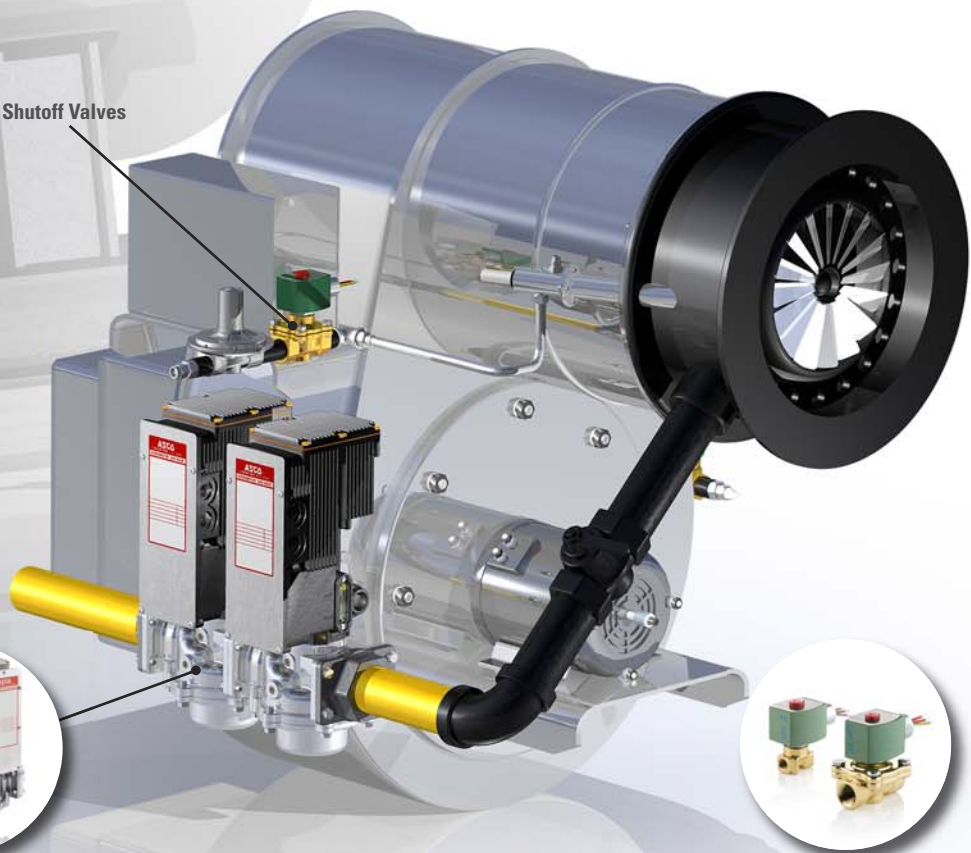

ASCO Modular Gas Shutoff Valves

These consistently outperform the competition in weight, size, flow, and power consumption. Get the modular flexibility to configure gas trains for your needs, from the exceptionally small footprint permitted by our double solenoid models to the high flows of our double electric-actuated valves. Increase savings with direct piping or choose ease of installation and maintenance with NPT threaded flange adapters and bodies.



ASCO General Purpose Solenoid Valves

Select from the widest range of solenoid valves on the market to find plenty of proven models for air or liquid flow. High flows provide users with more cycles and greater throughput. Apply these valves on boiler water feed lines and all other general service (air/water/light oil) applications.



Ideal for all your applications

ASCO Numatics furnishes complete solutions for a broad range of heating equipment. These include:

- Boilers
- Burners
- Furnaces
- Ovens
- Kilns
- Incinerators

Whether it's a steam valve on a boiler generating process steam, a combustion valve for fuel oil or gas shutoff on an oven burner, or a general-purpose water valve supplying a boiler's feedwater, ask for ASCO Numatics. Users find our products are their ideal first choices for cost-efficient automation all across the application categories listed below.

Nonresidential comfort heating. This category includes thermostatically controlled warm air furnaces that provide clean, heated air to maintain comfortable indoor environments in nonresidential facilities. Temperature-controlled burner boilers furnish hot water and steam for facility heating, plus hot water for facility kitchens, rest rooms, and maintenance areas.

Commercial/industrial heating. These applications include burners providing heat to equipment such as dishwashers, laundries, sterilizers, fryers, ovens, furnaces, kilns, incinerators, stokers, and boilers. Equipment in these categories performs washing, cleaning, food cooking and warming, drying, curing, annealing, and other essential tasks.

Process heating. This applications group includes large burners generating heat to refine and produce end products in process plants for pharmaceuticals, pulp and paper, oil and gas, biofuels, and other industries.

Power and steam. These applications typically involve large burner boilers that use natural resources such as coal, oil, natural and mixed gas, and waste products to produce steam that drives large turbines for the production of electrical power.

In all these application areas and more, users report that ASCO Numatics automation products deliver the best combination of value and performance.

Known for leadership worldwide

ASCO Numatics, a division of Emerson, offers comprehensive flow control and pneumatics solutions for a wide range of industry-focused applications. The ASCO Numatics line comprises more than 50,000 valves, an extensive selection of air preparation equipment, and a comprehensive line of motion control products. The company is the world's leading manufacturer of solenoid valves.

Emerson (NYSE: EMR), based in St. Louis, Missouri, U.S.A., is a global leader in bringing technology and engineering together to create innovative solutions for customers through its network power, process management, industrial automation, climate technologies, and appliance and tools businesses. Sales in fiscal 2009 were \$20.9 billion.

Global Contacts

www.asconumatics.com

ASCO

<u>Location</u>	<u>Phone</u>
World Headquarters (U.S.A.)	(1) 800-972-ASCO (2726)
Canada	(1) 519-758-2700
Mexico	(52-55) 5809-5640

E-mail: info-valve@asco.com

NUMATICS

<u>Location</u>	<u>Phone</u>
World Headquarters (U.S.A.)	(1) 888-Numatics (686-2842)
Canada	(1) 519-452-1777
Mexico	(52) 222-284-6176

E-mail: InsideSales@numatics.com



Other Worldwide locations

<u>Location</u>	<u>Phone</u>
Australia	(61) 2-9-451-7077
Brazil	(55) 11-4208-1660
China	(86-10) 8563-1122
France	(33) 1-47-14-32-00
Germany	(49) 7237-9960
Japan	(81) 798-65-6361
Singapore	(65) 6556-1100
United Kingdom	(44) 1695-713600

ASCO
numatics™